

**FEATURES**

- Accurate and precise flow measurement
- Accurate and precise flow balancing
- Positive shut-off
- “Y” Pattern Globe style design
- Multi-turn, 360° handwheel with vernier scale and digital readout
- Built in memory stop
- Offsetting Pressure/Temperature ports, self sealing with optional Drain Kits
- Wide variety of accessories available

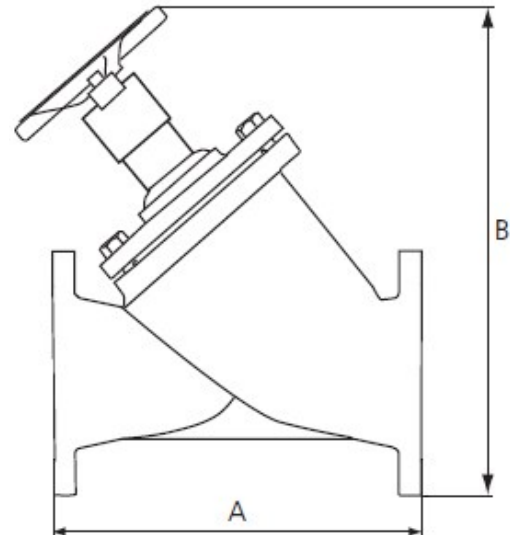

SPECIFICATIONS	
Pressure Ratings:	235 psi / 16 bar (PN 16)
Temperature Ratings:	14°F to 248°F (-10°C to 120°C)
Body:	Cast Iron
End Connections:	ANSI 125# Flanged
Gaskets:	EPDM
Seat Seal	PTFE
Handwheel:	Polyamide Plastic

NOMINAL DIMENSIONS & WEIGHTS								Valve Selection Guide				
MODEL	SIZE			A Length	B Height	WEIGHT		Handwheel Turns		Minimum Flow	Nominal Range of Flow	Maximum Flow
	in	mm				lbs	kg					
STVE-0800	8.0"	200	in	23.6	13.5	260	118	11	GPM	30	450 - 750	2415
			mm	600	343				LPM	114	1703 - 2839	9142
STVE-1000	10.0"	250	in	28.7	16.0	390	177	11	GPM	47	750 - 1300	4050
			mm	730	406				LPM	178	2839 - 4921	15330
STVE-1200	12.0"	300	in	33.5	19.0	490	223	11	GPM	43	1300 - 1600	5115
			mm	850	483				LPM	163	4921 - 6057	19360

FLOW CALCULATIONS
The Minimum Flow is calculated from the minimum recommended pressure drop, 1 ft WG (=3.0 kPa)
The Nominal Flow is calculated from the maximum setting of the valve and the minimum recommended pressure drop, 2 ft WG (=6.0 kPa)
The Maximum Flow is calculated from the maximum setting of the valve and the maximum pressure drop, 20 ft WG (=60.0 kPa)

Optional features and accessories available for this Macon product are an extra charge, and not included in the standard model price.  
www.maconbalancing.com



Tunstall Corporation  
118 Exchange Street · Chicopee, MA 01013  
Phone (413) 594-8695 · Fax (413) 598-8109  
Section: Components      Bulletin-MB-STVE-1016.03

# Pressure Drop Tables - Model STVE—Sizes 8.00" to 12.00"

## Series STVE 8.00" - 12.00"

This diagram details the relationship between flow, pressure drop and valve preset points. Use the diagram to select the correct valve size and corresponding handwheel setting to fulfill the application requirements.

Determine the required flow in the circuit (A) and the pressure drop (B). Draw a line between these two values. Read off the corresponding Cv value on the Cv scale (C).

Determine the valve setting, in handwheel turns, by drawing a horizontal line (D) from the intersection point on the Cv scale to the corresponding valve setting position.

For the highest level of accuracy, it is recommended to choose a valve that has at least 3 open turns.

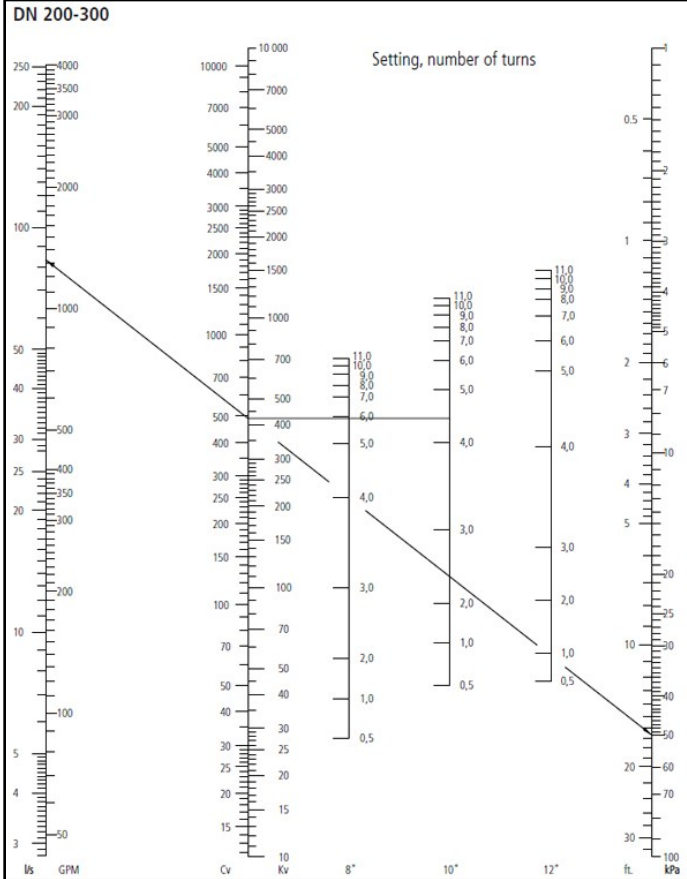

### Cv Values for Valve Series STVE

Flow coefficient values (Cv's)  
at various handwheel settings

Handwheel Setting	8" DN 200	10" DN 250	12" DN 300
0.5	32	50	52
1	45	72	66
1.5	53	85	83
2	63	101	104
2.5	82	134	127
3	115	189	163
3.5	172	277	234
4	250	399	383
4.5	328	522	578
5	394	628	733
5.5	448	719	848
6	497	802	954
6.5	545	881	1067
7	587	952	1177
7.5	619	1013	1272
8	648	1070	1352
8.5	682	1126	1422
9	716	1182	1486
9.5	745	1234	1549
10	771	1283	1612
10.5	796	1330	1675
11	821	1373	1739

**Example:** A 10" valve is required to be open 4.3 turns for a Cv value of 500 at a flow rate of 1300 gpm and a pressure drop of 17 ft.

### Installation Recommendations

Install the valve in the correct flow direction according to the arrow on the valve body and the distance parameters detailed in Figure 1 (Note: D = pipe diameter).

When used with a pump, it is recommended to use a straight length of pipe totaling 10 x D (instead of 5 x D) upstream or downstream to avoid turbulence that will affect the measuring accuracy. See Figure 2.

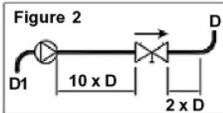
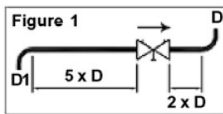

Turbulence can influence the measurements by up to 20% if this recommendation is not followed.

### Flow Measurement & Accuracy

The measuring instrument connects to the test ports of the valve and is pre-programmed with Macon Balancing characteristics. The pressure drop and flow readings can be read off the display. If access to a Macon Balancing instrument is unavailable, other industry models are compatible. In addition, the flow can be determined using the pressure drop diagram that is included in the operating instructions with each Macon Balancing valve.

The accuracy is highest when the valve is fully open. Therefore, it is recommended to choose a valve that can be opened at least three turns

at the calculated pre-setting value. Figure 3 represents the flow measurement deviation in relation to handwheel turns.

### Correction for Liquids

Figure 3

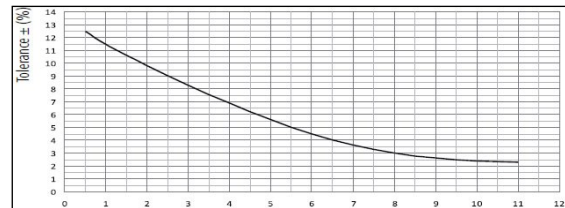

Applies to liquids other than water. Correct the measured flow (q) by the density (Y) according to this formula. See Figure 4

Figure 4  
**Actual Flow =  $\frac{q_{CB}}{\sqrt{Y}}$**

### Sizing a Balancing Valve

When the differential pressure and design flow are known, use this formula to calculate Cv value. See Figure 5

Figure 5  
 **$C_v = 1.52 \frac{q}{\sqrt{\Delta p}}$**   
q in GPM, Δp in Ft. of H<sub>2</sub>O

**$C_v = \frac{q}{\sqrt{\Delta p}}$**   
q in GPM, √p in PSI